

MODULATOR SERIES SPEAKER ARRAYS



INSTALLATION AND MAINTENANCE INSTRUCTIONS

Copyright 2007 Federal Signal Corporation

SAFETY NOTICES

People's lives depend on your selection of suitable equipment and installation sites and your safe installation, service, and operation of our products. Federal Signal recommends the following publications from the Federal Emergency Management Agency for assistance with planning an outdoor warning system: 1. The "Outdoor Warning Guide (CPG 1-17), 2. "Civil Preparedness, Principles of Warning" (CPG 1-14), 3. FEMA-REP-1, Appendix 3 (Nuclear Plant Guideline), and 4. FEMA-REP-10 (Nuclear Plant Guideline). Contact Federal Warning System's Customer Care Center at: <http://www.federalwarningsystems.com> or 1-800-524-3021 for further information about these publications.

It is important to read, understand and follow all instructions shipped with this product. In addition, listed below are some other important safety instructions and precautions you should follow.

PLANNING

- If suitable warning equipment is not selected, the installation site for the siren is not selected properly or the siren is not installed properly, it may not produce the intended optimum audible warning. Follow Federal Emergency Management Agency (FEMA) recommendations.
- If sirens are not activated in a timely manner when an emergency condition exists, they cannot provide the intended audible warning. It is imperative that knowledgeable people, who are provided with the necessary information, are available at all times to authorize the activation of the sirens.
- When sirens are used out of doors, people indoors may not be able to hear the warning signals. Separate warning devices or procedures may be needed to effectively warn people indoors.
- The sound output of sirens is capable of causing permanent hearing damage. To prevent excessive exposure, carefully plan siren placement, post warnings, and restrict access to areas near sirens.
- Activating the sirens may not result in people taking the desired actions if those to be warned are not properly trained about the meaning of siren sounds. Siren users should follow FEMA recommendations and instruct those to be warned of correct actions to be taken.
- A siren that doesn't work won't provide any warning. After installation, service, or maintenance, test the siren system to confirm that it is operating properly. Test the system regularly to confirm that it will be operational in an emergency.
- If future service and operating personnel do not have these instructions to refer to, the siren system may not provide the intended audible warning and service personnel may be exposed to death, permanent hearing loss, or other bodily injury. File these instructions in a safe place and refer to them periodically. Give a copy of these instructions to new recruits and trainees. Also give a copy to anyone who is going to service or repair the siren.

SAFETY NOTICES

People's lives depend on your safe installation, service and operation of our products. It is important to read, understand and follow all instructions shipped with this product. In addition, listed below are some other important safety instructions and precautions you should follow:

INSTALLATION & SERVICE

- Electrocutation or severe personal injury can occur when performing various installation and service functions such as making electrical connections, drilling holes, or lifting equipment. Therefore experienced electricians in accordance with national, state and any other electrical codes having jurisdiction should perform installation. All work should be performed under the direction of the installation or service crew safety foreman.
- The sound output of sirens is capable of causing permanent hearing damage. To prevent excessive exposure, carefully plan siren placement, post warnings and restrict access to areas near the sirens. Sirens may be operated from remote control points. Whenever possible, disconnect all siren power including batteries before working near the siren.
- After installation or service, test the siren system to confirm that it is operating properly. Test the system regularly to confirm that it will be operational in an emergency.
- If future service personnel do not have these warnings and all other instructions shipped with the equipment to refer to, the siren system may not provide the intended audible warning and service personnel may be exposed to death, permanent hearing loss, or other bodily injury. File these instructions in a safe place and refer to them periodically. Give a copy of these instructions to new recruits and trainees. Also, give a copy to anyone who is going to service or repair the sirens. For additional copies, call the Federal Warning Systems Customer Care Center at 800-524-3021 or write to them at 2645 Federal Signal Drive, University Park, IL 60466.

OPERATION

- Failure to understand the capabilities and limitations of your siren system could result in permanent hearing loss, other serious injuries or death to persons too close to the sirens when you activate them or to those you need to warn. Carefully read and thoroughly understand all safety notices in this manual and all operations-related-items in all instruction manuals shipped with equipment. Thoroughly discuss all contingency plans with those responsible for warning people in your community, company, or jurisdiction.

Limited Warranty

*The Federal Warning Systems Division of **Federal Signal Corporation** warrants each new product to be free from defects in material and workmanship, under normal use and service, for a period of two years on parts replacement and factory-performed labor (one year for Informer, EAS, and Federal software products) from the date of delivery to the first user-purchaser. Federal Warning Systems warrants every 2001 & Eclipse Siren (Top of pole only) to be free from defects in material, per our standard warranty, under normal use and service for a period of five years on parts replacement.*

During this warranty period, the obligation of Federal is limited to repairing or replacing, as Federal may elect, any part or parts of such product which after examination by Federal discloses to be defective in material and/or workmanship.

Federal will provide warranty for any unit which is delivered, transported prepaid, to the Federal factory or designated authorized warranty service center for examination and such examination reveals a defect in material and/or workmanship.

This warranty does not cover travel expenses, the cost of specialized equipment for gaining access to the product, or labor charges for removal and re-installation of the product. The Federal Signal Corporation warranty shall not apply to components or accessories that have a separate warranty by the original manufacturer, such as, but not limited to, batteries.

Federal will provide on-site warranty service during the first 60-days after the completion of the installation, when Federal has provided a turn-key installation including optimization and/or commissioning services.

This warranty does not extend to any unit which has been subjected to abuse, misuse, improper installation or which has been inadequately maintained, nor to units which have problems related to service or modification at any facility other than Federal factory or authorized warranty service centers. Moreover, Federal shall have no liability with respect to defects arising in Products through any cause other than ordinary use (such as, for example, accident, fire, lightning, water damage, or other remaining acts of god).

THERE ARE NO OTHER WARRANTIES, EXPRESSED OR IMPLIED, INCLUDING BUT NOT LIMITED TO, ANY IMPLIED WARRANTIES OF MERCHANTABILITY OR FITNESS FOR A PARTICULAR PURPOSE. IN NO EVENT SHALL FEDERAL BE LIABLE FOR ANY LOSS OF PROFITS OR ANY INDIRECT OR CONSEQUENTIAL DAMAGES ARISING OUT OF ANY SUCH DEFECT IN MATERIAL WORKMANSHIP.



FEDERAL SIGNAL

Federal Warning Systems

2645 Federal Signal Drive, University Park, IL 60466

Phone: (800) 524-3021 Fax: (708) 534-4865

Website: <http://www.federalwarningsystems.com>

TABLE OF CONTENTS

Paragraph		Page
SECTION I – CHARACTERISTICS		
1-1	Scope of this Manual.....	1-1
1-2	General	1-1
1-3	Siren Description.....	1-1
1-4	Frequency Response.....	1-1
1-5	Features	1-1
SECTION II - SPECIFICATIONS		
2-1	Siren	2-1
SECTION III – INSTALLATION		
3-1	Siren Location	3-1
3-2	Siren Installation	3-2
3-3	Speaker Connections (excluding MOD6032)	3-4
3-4	MOD6032 Speaker Connections.....	3-6
3-5	Pre-operation Checkout.....	3-7
SECTION IV - SERVICE AND MAINTENANCE		
4-1	General	4-1
4-2	Preventive Maintenance	4-1
4-3	Driver Replacement.....	4-1

SECTION I CHARACTERISTICS

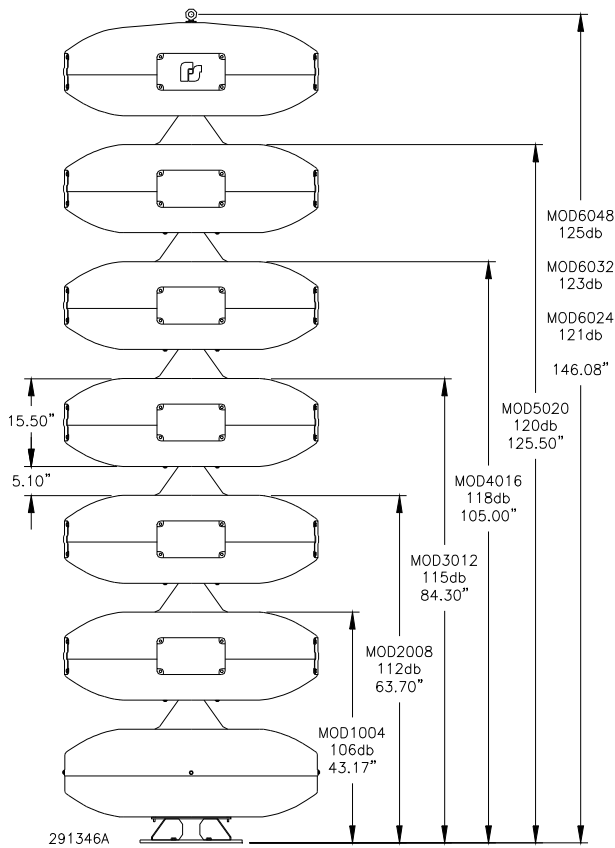

Figure 1-1. Modulator Series Outline Drawing

1-1. SCOPE OF THIS MANUAL

This service manual describes the characteristics, specifications, installation, theory of operation, and service and maintenance of the Federal Modulator Series Outdoor Warning Siren speaker arrays.

1-2. GENERAL

Federal Signal's Modulator Series siren products are a family of electronic sirens that are

capable of producing high intensity warning signals over a large area. The siren consists of a speaker array (Figure 1-1) and a control unit/battery box. A highly efficient design enables the siren to produce a high sound level, while making moderate demands on the power source.

1-3. SIREN DESCRIPTION

Federal Signal's innovative omni directional, electronic Modulator Series siren consists of aluminum modules that utilize four or eight 100 Watt drivers per module. The Modulator series is available in several models which have the following sound output rating at 100 feet.*

MOD1004	106 dBC
MOD2008	112 dBC
MOD3012	115 dBC
MOD4016	118 dBC
MOD5020	120 dBC
MOD6024	121 dBC
MOD6032	123 dBC
MOD6048	125 dBC

*Based on measurements at 500 feet.

1-4. FREQUENCY RESPONSE

The Modulator Series siren provides virtually flat frequency response from 200 - 2000 Hertz. This gives the siren the ability to produce loud and clear voice messages as well as the ability to produce a full spectrum of warning tones.

1-5. FEATURES

An UltraVoice Series control unit (UV) is needed for complete operation.

SECTION II SPECIFICATIONS

2-1. SIREN

Color	Weather Guard White II
Paint Type.....	TGIC Polyester Powder coat
Modular Horn Type.....	Hyperbolic Flare
Frequency Response	200 – 2000 Hz
Horizontal Coverage.....	360 Degrees
Bottom (non-active) Module* Dimensions	15-1/2 x 44-1/2" Diameter (See Fig. 1-1)

MOD1004

Number of Active Modules.....	1
Power.....	400 Watts
dB Output.....	106 dBC @100 feet
Height of Speaker Array.....	43.17"
Weight.....	181 lbs.
EPA at 40'	8 ft2
Wind Load (110 mph, 40' above ground)	568 lbs.

MOD2008

Number of Active Modules.....	2
Power.....	800 Watts
dB output.....	112 dBC @100 feet
Height of Speaker Array.....	63.70"
Weight.....	296 lbs.
EPA at 40'	12 ft2
Wind Load (110 mph, 40' above ground)	851 lbs.

MOD3012

Number of Active Modules.....	3
Power.....	1200 Watts
dB output.....	115 dBC @ 100 feet
Height of Speaker Array.....	84.30"
Weight.....	411 lbs.
EPA at 40'	17 ft2
Wind Load (110 mph, 40' above ground)	1135 lbs.

*The bottom module of the siren is a passive device that does not contain any drivers. Its functional use is to complete the horn formed by the bottom and the first active module.

MOD4016

Number of Active Modules	4
Power.....	1600 Watts
dB output.....	118 dBC @ 100 feet
Height of Speaker Array.....	105.00"
Weight.....	526 lbs.
EPA at 40'	21 ft2
Wind Load (110 mph, 40' above ground)	1419 lbs.

MOD5020

Number of Active Modules	5
Power.....	2000 Watts
dB output.....	120 dBC @ 100 feet
Height of Speaker Array.....	125.50"
Weight.....	640 lbs.
EPA at 40'	25 ft2
Wind Load (110 mph, 40' above ground)	1703 lbs.

MOD6024

Number of Active Modules	6
Power.....	2400 Watts
dB output.....	121 dBC @ 100 feet
Height of Speaker Array.....	146.08"
Weight.....	760 lbs.
EPA at 40'	29 ft2
Wind Load (110 mph, 40' above ground)	1987 lbs.

MOD6032

Number of Active Modules	6
Power.....	3200 Watts
dB output.....	123 dBC @ 100 feet
Height of Speaker Array.....	146.08"
Weight.....	861 lbs.
EPA at 40'	29 ft2
Wind Load (110 mph, 40' above ground)	1987 lbs.

MOD6048

Number of Active Modules	6
Power.....	4800 Watts
dB output.....	125 dBC @ 100 feet
Height of Speaker Array.....	146.08"
Weight.....	928 lbs.
EPA at 40'	29 ft2
Wind Load (110 mph, 40' above ground)	1987 lbs.

SECTION III INSTALLATION

DANGER

Electrocution or severe personal injury can occur when making electrical connections, drilling holes, or lifting equipment. Therefore, installation should be performed by experienced electricians in accordance with national and local electrical codes.

3-1. SIREN LOCATION

The information in this section provides guidelines to aid the user in the selection of an installation site that makes the best possible use of the siren.

WARNING

The output level of a Modulator Series siren is capable of causing permanent hearing damage. To prevent excessive exposure, carefully plan placement of siren and post warnings.

If the siren is being installed as part of a Civil Defense Warning system, ALWAYS follow Federal Emergency Management Agency (FEMA) recommendations.

Careful consideration of the factors affecting the propagation of sound from the siren and the response of the human ear to the sound will optimize the ability of the siren to effectively warn the community outdoors.

The reduction of signal intensity, as the distance from the siren increases and the minimum desired signal level at the fringe of the outdoors area to be covered are important considerations when choosing a siren installation site. As the distance from the siren increases, sound level losses accumulate. These losses are a result of weather conditions, the terrain, obstructions in the sound path, the pitch of the sound and the height of the siren.

Optimum sound propagation conditions exist when there are no obstructions in the sound path, the terrain is flat, and the air is calm. Under these conditions, each time the distance from the siren is doubled, the sound level decreases by approximately 10dB. For example, the sound level at 100 feet (30.5m) from a MOD6024 is 121dB. At 200 feet

(61m), the level drops to 111dB; at 400 feet (122m) the sound level drops to 101dB; etc. This is referred to as the "loss per distance doubled".

A loss per distance doubled of 10dB is usually experienced because buildings and other obstructions are frequently present in the sound path. In addition, the atmosphere is rarely calm, the terrain may not be flat, and humidity conditions may vary. As a result, a typical loss per distance doubled in residential areas may be 10dB, and as high as 12dB in areas having tall buildings or other factors detrimental to sound propagation. Ideally in a free field the loss would be 6dB per distance doubled.

Experience indicates an individual with normal hearing will probably hear a warning signal whose intensity is at least as high as the ambient noise level.

Experience has also shown that the ambient outdoor noise level in industrial districts is typically 90dB. Therefore, for a person to hear a warning signal in an industrial area, the sound level intensity of that signal must also be at least 90dB. In this situation, any point receiving a signal having less than 90dB intensity is considered to be outside the effective range of the siren.

In business districts an ambient noise level of 80dB is common, and in residential areas, 68dB of ambient noise is typical. Assuming a 10dB loss per distance doubled and a 68dB minimum sound level, the effective range of the MOD6024 is approximately 3900 feet.

Wind speed and direction often affect the propagation of sound from the siren. Consequently, the direction of the prevailing wind may also be a factor to consider when selecting the installation site(s) of a small, one or two-siren system. For example, if the prevailing wind is from the west, it may be desirable to install the siren toward the western edge of the area to be covered.

Other factors to consider before selecting the installation site include the availability of electrical power, the ease of installation and maintenance, the height of surrounding obstructions, and security against vandalism.

3-2. SIREN INSTALLATION

A. General.

Most siren installations are one of two types: Pole Mount or Flat Surface Mount. These two configurations make it possible to install a siren in almost any situation. If the installations in this section are not suitable, modification of one of the configurations may be practical.

A siren is typically installed 40 to 50 feet above the ground. If the installation is located less than 50 feet above the ground, the sound intensity at close range may increase, but at the same time the effective range of the siren may be reduced. Conversely, if the siren is located more than 50 feet above ground, the effective range of the siren may increase, but the sound may skip over areas closer to the siren. These variables may make it desirable to test the sound coverage of the siren at various heights and locations whenever possible.

NOTE: To protect the speaker arrays from damage during shipping, all models have been shipped without drivers installed.

After uncrating the siren remove the four (4) inspection doors from each individual active module by removing the four (4) bolt and washer sets of each door. Note the position of the flat washer and lock washer.

The drivers should be threaded clockwise onto the horn throats. Hand tighten approximately 1/2 turn after gasket engagement. Locate the two (2) wires tie wrapped near the end of the horn throat. Note the label on the back of the drivers and connect the solid wire to terminal 1 and the striped wire to terminal 2 and white jumpers from 1 to 2 as shown in *Figure 3-7. Driver Orientation.*

WARNING

CONNECTING DRIVER WIRES OUT OF PHASE MAY CAUSE SEVERE REDUCTION IN SOUND OUTPUT.

B. Wooden Pole Mounting.

A typical wooden pole-mounted siren installation is shown in *Figure 3-2*. The siren is mounted on a Class 2 utility pole (ANSI type wooden pole or equivalent) with a minimum horizontal ground stress rating of 3,700 pounds (1682 kg). Insure that soil loads will conform to this size utility pole. It is attached to the pole by means of legs, as shown in *Figure 3-1*.

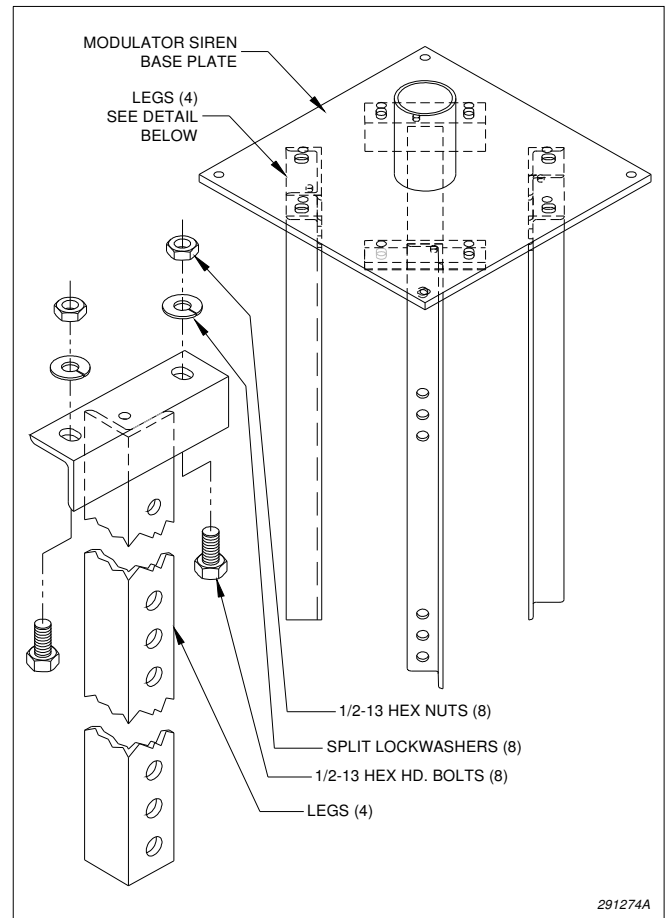

Figure 3-1. Siren Leg Assembly

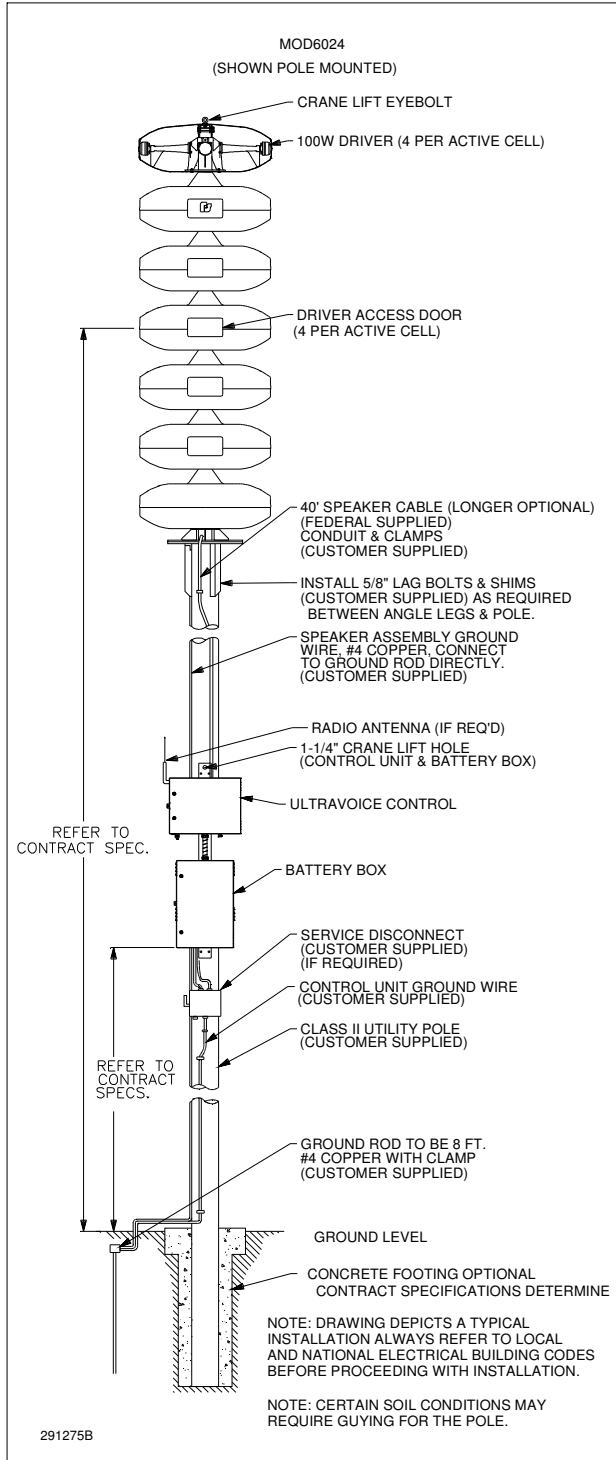

Figure 3-2. Typical Wooden Pole-mounted Installation

Using the 3 ft. long angle iron legs, the siren is mounted on the Class 2 utility pole as follows:

1. Uncrate the siren. Remove and dispose of any hardware that holds the siren on the shipping

base. Install drivers if needed (see NOTE on previous page). Lift the siren approximately 3-1/2 ft. with a crane or hoist.

2. Install the four legs on the siren mounting plate, as shown in Figure 3-1. Use two stainless steel 1/2" bolts, nuts and lock washers (provided) for each leg. All mounting hardware needed is supplied in the hardware kit shipped with this manual. Do not tighten the bolts completely.

WARNING

The eyebolt does NOT have sufficient strength to support the combined weight of the siren and a utility pole. Therefore, do NOT attempt to erect the pole and siren together using the eyebolt as a lifting point.

3. Erect the utility pole in accordance with accepted practices and FEMA guidelines.

4. Raise the siren to the necessary height, and lower it over the pole. Maintain tension on lifting chain until all bolts are tightened.

5. Adjust the legs and insert shims, if necessary, between the siren legs and pole. Bolt the siren to the pole using two user supplied 5/8" lag bolts, at least four inches long for each leg. Tighten all bolts, including those from step 2 above.

C. Steel Pole Mounting.

In a typical steel pole-mounted siren installation the MOD1004 and MOD2008 sirens are mounted on a Grade A Standard galvanized steel pole. The MOD3012, MOD4016, MOD5020, MOD6024, MOD6032, and MOD6048 are mounted on a Grade A Heavy galvanized steel pole. (Insure that soil loads will conform to this size utility pole).

1. Erect the steel utility pole in accordance with accepted practices and FEMA guidelines.

2. Uncrate the siren. Remove and dispose of any hardware that holds the siren on the shipping base. Install drivers (see NOTE on previous page). Lift the siren with a crane or hoist to the necessary height and lower it over the pole. Maintain tension on lifting chain until all bolts are tightened.

WARNING

The eyebolt does NOT have sufficient strength to support the combined weight of the siren and a utility pole. Therefore, do NOT attempt to erect the pole and siren together using the eyebolt as a lifting point.

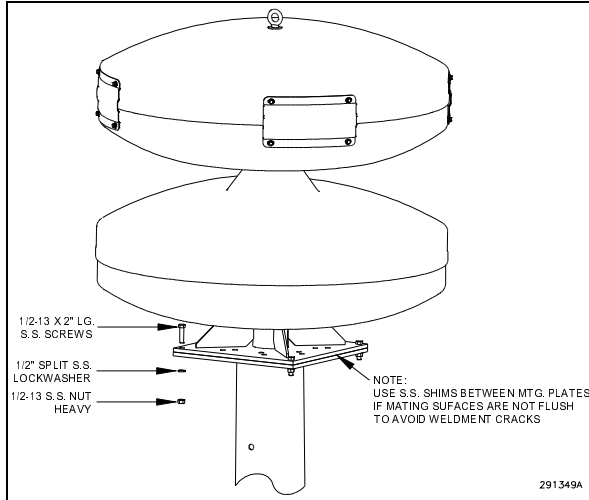

Figure 3-3. Steel Pole Mounting

3. Attach the modulator base to the pole's top plate with four of the stainless steel 1/2" bolts, nuts, and lock washers provided (see Figure 3-3). All

mounting hardware needed is supplied in the hardware kit shipped with this manual. Not all the hardware in the kit will be used in this type of installation. Before tightening bolts, check mounting surfaces for warping. If modulator base and top plate of pole have a gap greater than approximately 1/16" between them, install galvanized shims to even out. Tighten bolts to 45 - 46 ft/lb torque.

D. Flat Surface Mount.

This installation configuration is practical when the installation site is on a flat roofed building. The siren can be anchored directly to the roof, on a platform as shown in Figure 3-5, or on a weight distribution mat like the one shown in Figure 3-4.

NOTE: A qualified Professional Engineer should approve mounting locations, materials and methods prior to installation.

This mat is required when the siren mounting surface is unable to support over 176 pounds per square foot (859 kg per square meter). The mat shown in Figure 3-4 distributes the siren weight to approximately 25 pounds per square foot (122 kg per square meter). When installing the siren on a flat roof, be sure that it clears the parapets or other obstructions by at least ten feet.

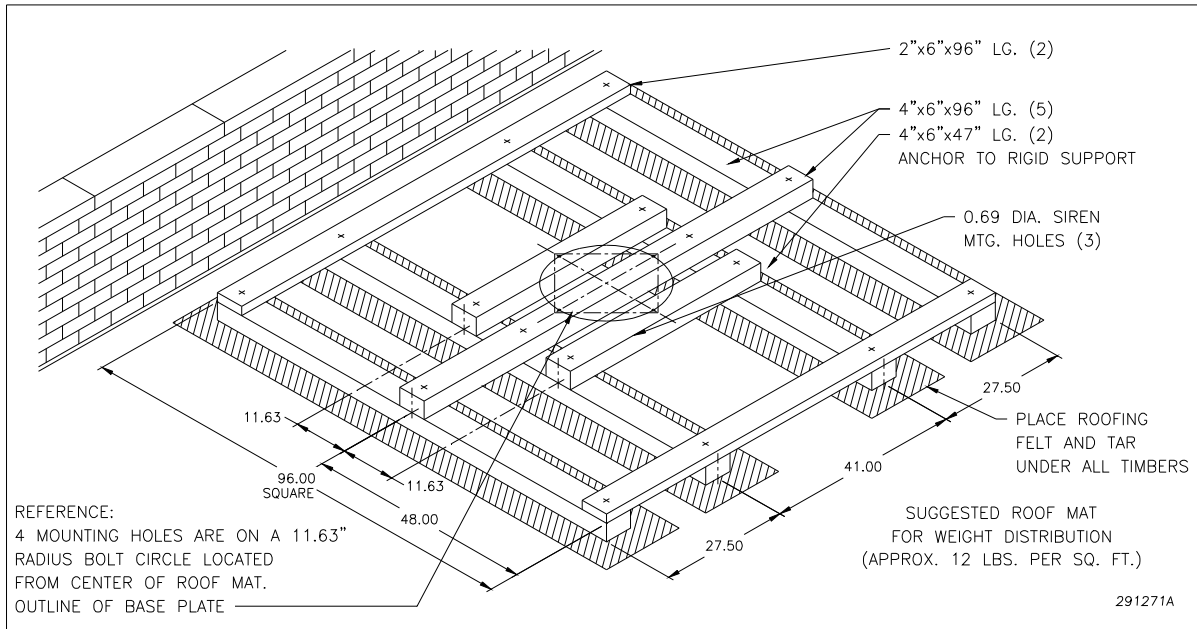

Figure 3-4. Weight Distribution Mat Construction.

To install a Modulator Series siren on a flat roof or other flat surface, proceed as follows:

1. If desired, construct a platform for mounting the siren, which must be capable of supporting at least 800 lbs. as well as withstanding a siren wind load of 100 mph. The platform must also be capable of distributing its own weight plus the siren to a value that is safe for the mounting surface. Platform design and construction details are left to the installer. Locate the platform at the siren installation site. Using suitable hardware (not supplied), anchor the platform to the mounting surface.

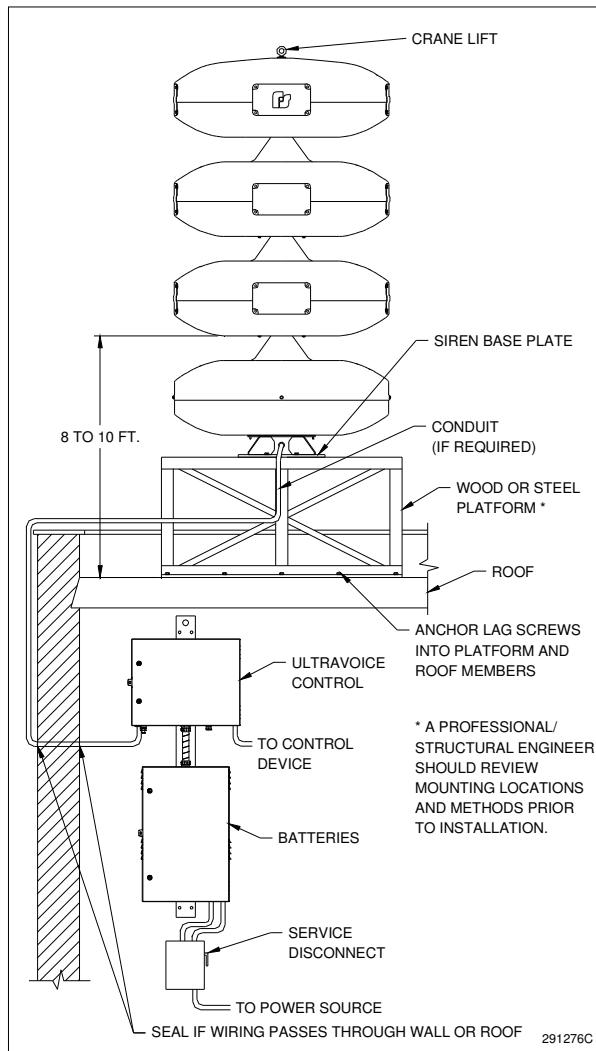

Figure 3-5. Typical Surface-mounted Siren Installation

WARNING

The eyebolt and hoisting bracket do not have sufficient strength to support the combined weight of the siren and

the platform. Therefore, do NOT lift the siren and platform together using the eyebolt as a lifting point.

2. Hoist the siren to the installation site using the eyebolt as a lifting point (refer to WARNING above).

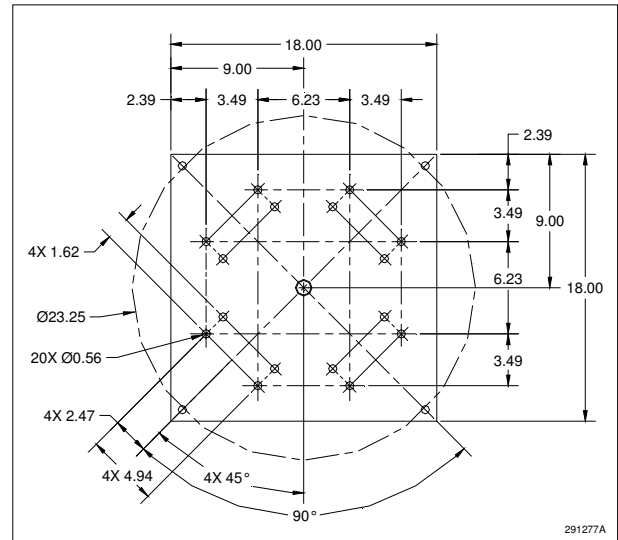

Figure 3-6. Siren Base Plate

3. Anchor the siren to the mounting surface with a user supplied 1/2" lag bolts or nuts and bolts, as appropriate through the mounting holes (one in each corner) in the siren base plate (see Figure 3-6). If the siren is mounted directly on a roof, (without a platform or weight distribution mat) be sure to install user supplied waterproof joints at the points where the mounting bolts pass through the roof so that water does not enter the building.

3-3. SPEAKER CONNECTIONS (excluding MOD6032)

Depending on the model of siren used the number of speaker connections and colors will vary. This is due to the different number of drivers required for each model. In any case OBSERVE PROPER POLARITY when making these connections. The striped wire is common and goes to position 2. The solid colored wire is signal high and goes to position 1. Each speaker connection is color-coded. Refer to Figure 3-7 for wiring and position.

ACTIVE MODULE	DRIVER-TERMINAL	WIRE COLOR
1	A - 1	BROWN
	B - 2	WHT/BRN
	C - 1	RED
	D - 2	WHT/RED
2	E - 1	ORANGE
	F - 2	WHT/ORG
	G - 1	YELLOW
	H - 2	WHT/YEL
3	I - 1	GREEN
	J - 2	WHT/GRN
	K - 1	BLUE
	L - 2	WHT/BLU
4	M - 1	VIOLET
	N - 2	WHT/VIO
	O - 1	GRAY
	P - 2	WHT/GRY
5	Q - 1	WHITE
	R - 2	BLK/WHT
	S - 1	TAN
	T - 2	WHT/TAN
6	U - 1	BLACK
	V - 2	WHT/BLK
	W - 1	PINK
	X - 2	WHT/PNK

291279B

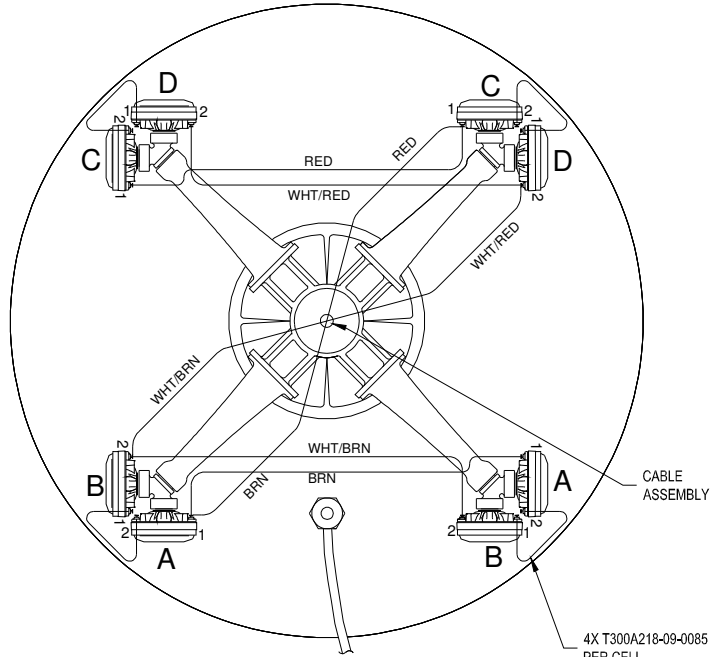

TOP VIEW
DRIVER ORIENTATION
 (FIRST ACTIVE MODULE - MOD6048 ONLY)

WIRE THE FOLLOWING DRIVERS DIRECTLY ABOVE DRIVERS A & B:
 E & F, I & J, M & N, Q & R, AND U & V.

ACTIVE MODULE	DRIVER-TERMINAL	WIRE COLOR
1	A - 1 / A - 2	BROWN /WHT(JUMP)
	B - 1 / B - 2	WHT(JUMP) /WHT/BRN
	C - 1 / C - 2	WHT(JUMP) / WHT/BRN
	D - 1 / D - 2	BROWN /WHT(JUMP)
2	E - 1 / E - 2	RED /WHT(JUMP)
	F - 1 / F - 2	WHT(JUMP) /WHT/RED
	G - 1 / G - 2	WHT(JUMP) / WHT/RED
	H - 1 / H - 2	RED /WHT(JUMP)
3	I - 1 / I - 2	ORANGE /WHT(JUMP)
	J - 1 / J - 2	WHT(JUMP) /WHT/ORG
	K - 1 / K - 2	WHT(JUMP) / WHT/ORG
	L - 1 / L - 2	ORANGE /WHT(JUMP)
4	M - 1 / M - 2	YELLOW /WHT(JUMP)
	N - 1 / N - 2	WHT(JUMP) / WHT/YEL
	O - 1 / O - 2	WHT(JUMP) / WHT/YEL
	P - 1 / P - 2	YELLOW /WHT(JUMP)
5	Q - 1 / Q - 2	GREEN /WHT(JUMP)
	R - 1 / R - 2	WHT(JUMP) /WHT/GRN
	S - 1 / S - 2	WHT(JUMP) / WHT/GRN
	T - 1 / T - 2	GREEN /WHT(JUMP)
6	U - 1 / U - 2	BLUE /WHT(JUMP)
	V - 1 / V - 2	WHT(JUMP) /WHT/BLU
	W - 1 / W - 2	WHT(JUMP) / WHT/BLU
	X - 1 / X - 2	BLUE /WHT(JUMP)

291278C

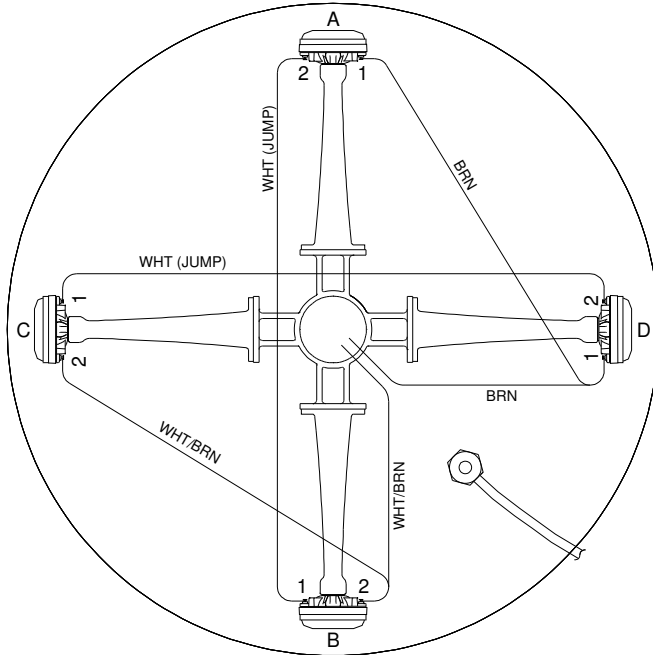

TOP VIEW
DRIVER ORIENTATION

Figure 3-7. Driver Orientation (excluding MOD6032)

The bottom module in the speaker array is an inactive module. This means there are no drivers contained in the module. The next module up is called module number one. The next one above module one is called module number two etc. These are referred to as active modules. Each active module contains four (4) drivers, however the MOD6048 contains eight (8) drivers per active module. Refer to *Figure 3-7* for driver orientation and wire location for active module one only.

Each speaker array is supplied with a 50 foot cable. The number of conductors and colors vary from module to module. Refer to the following list

for the number of wires per module and how many wires are used.

- MOD1004 - 4 wires, only 2 are used.
- MOD2008 - 4 wires, all are used.
- MOD3012 - 12 wires, only 6 are used.
- MOD4016 - 12 wires, only 8 are used.
- MOD5020 - 12 wires, only 10 are used.
- MOD6024 - 12 wires, all are used.
- MOD6048 - 24 wires, all are used.

3-4. MOD6032 SPEAKER CONNECTIONS

ACTIVE MODULE	DRIVER-TERMINAL	WIRE COLOR
1	A-1 / A-2	BROWN / WHT(JUMP)
	B-1 / B-2	WHT(JUMP) / WHT/BRN
	C-1 / C-2	WHT(JUMP) / WHT/BRN
	D-1 / D-2	BROWN / WHT(JUMP)
2	E-1 / E-2	ORANGE / WHT(JUMP)
	F-1 / F-2	WHT(JUMP) / WHT/ORG
	G-1 / G-2	WHT(JUMP) / WHT/ORG
	H-1 / H-2	ORANGE / WHT(JUMP)
3	I-1	GREEN
	J-2	WHT/GRN
	K-1	BLUE
	L-2	WHT/BLUE
4	M-1	VIOLET
	N-2	WHT/VIO
	O-1	GRAY
	P-2	WHT/GRAY
5	Q-1 / Q-2	WHT / WHT(JUMP)
	R-1 / R-2	WHT(JUMP) / BLK/WHT
	S-1 / S-2	WHT(JUMP) / BLK/WHT
	T-1 / T-2	WHT / WHT(JUMP)
6	U-1 / U-2	BLACK / WHT(JUMP)
	V-1 / V-2	WHT(JUMP) / WHT/BLK
	W-1 / W-2	WHT(JUMP) / WHT/BLK
	X-1 / X-2	BLACK / WHT(JUMP)

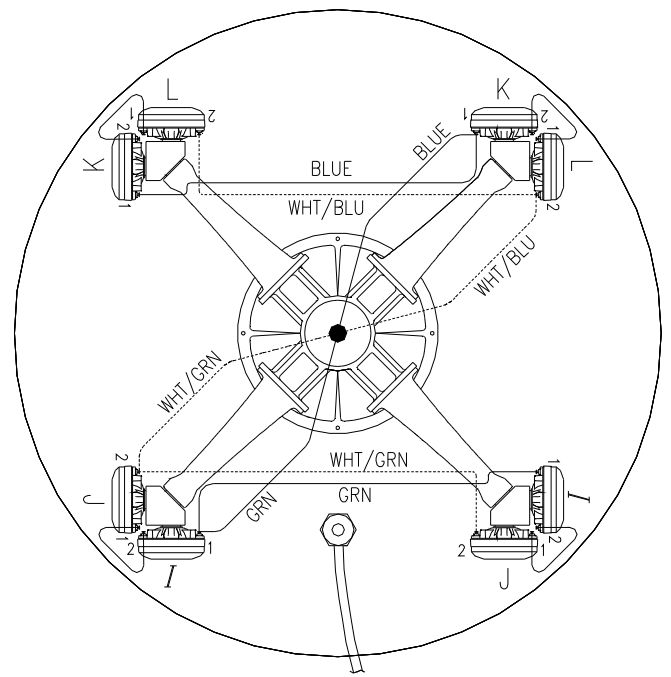

TOP VIEW
DRIVER ORIENTATION
(THIRD ACTIVE MODULE—MOD6032 ONLY)

WIRE DRIVERS M & N DIRECTLY ABOVE DRIVERS I & J.

291347A

Figure 3-8. MOD6032 Driver Orientation

OBSERVE PROPER POLARITY when making connections. The striped wire is common and goes to position 2. The solid colored wire is signal high and goes to position 1. Each speaker connection is color coded. Refer to *Figure 3-8* for wiring and position.

The bottom module in the speaker array is an inactive module. This means there are no drivers contained in the module. The next module up is called module number one. The next one above module one is called module number two, etc. These are referred to as active modules. Active modules #1, #2, #5, and #6 contain four (4) drivers each. Active modules #3 and #4 contain eight (8) drivers each. Refer to *Figure 3-8* for driver orientation and wire location for active module #3 only.

Each speaker array is supplied with a 50 ft cable. The number of conductors and colors vary from module to module. In a MOD6032, there are 24 wires with only 16 of those being used.

3-5. PRE-OPERATION CHECKOUT

After the siren has been completely installed, perform the following checks before putting the siren into service.

WARNING

The output sound level of a siren is capable of causing severe hearing discomfort or permanent hearing damage. Therefore, ALWAYS wear appropriate hearing protection when performing tests or maintenance on the siren, and post warnings to warn people before they are exposed to excessive sound pressure levels.

1. Make sure all connections in the Control Unit/Battery Box are correct and properly tightened.
2. Activate wail on the control panel. Check for proper sound output and siren tone.
3. After the installation is complete and it has been established that the siren is operating properly, Federal Signal recommends that all control devices be padlocked to discourage tampering and vandalism.

SECTION IV

SERVICE AND MAINTENANCE

4-1. GENERAL

WARNING

Service or maintenance should be performed by qualified personnel familiar with the siren, associated controls, and power sources being used.

The sound output of the siren is capable of causing permanent hearing damage. Use adequate hearing protection and avoid excessive exposure.

Before servicing or maintaining, ensure that remote activation cannot occur and disconnect power to the siren and its controls.

The Modulator Series Siren is designed to require a minimum of maintenance. In addition, experience has shown that all Federal sirens are highly reliable devices. However, if a siren failure does occur, Federal will provide technical assistance with problems that cannot be handled satisfactorily and promptly locally. If assistance is desired, contact:

Federal Warning Systems Customer Care Center
2645 Federal Signal Drive
University Park, Illinois 60466
800-524-3021

WARNING

The output level of a Modulator Series Siren is capable of causing permanent hearing damage. Therefore, ALWAYS wear hearing protection when performing tests or maintenance on the siren.

To prevent the siren from sounding always turn off the power to the siren at the disconnect switch and remove any DC power being supplied by the battery box before inspecting or maintaining the siren.

4-2. PREVENTIVE MAINTENANCE

Test the siren for proper operation at least once a month. A daily test at noon, curfew, or other selected time is preferred. This not only enhances the usefulness of the siren and verifies that it remains ready for use in an emergency, but instills public confidence in the reliability of the warning system.

In order to minimize the possibility of siren failure, annual inspection and maintenance is desirable.

Perform a driver inspection as described in Section 4-3.

4-3. DRIVER REPLACEMENT

To determine if a driver is bad refer to the procedure outlined in the installation instruction for the amplifier control unit or remove the speaker circuit from the terminal block and measure the impedance of the circuit. The impedance will measure approximately 2.7 ohms. If the reading is higher (5.4 ohms), one driver is bad. If the circuit is open, then either both drivers are bad or a wire has been severed.

To determine the location of the bad driver refer to the wiring table in Section 3 and *Figure 3-7 and Figure3-8*.

To replace a defective driver remove the four hex head 1/4 inch mounting bolts that are holding the inspection plate. Make sure the flat washer and split washer are not misplaced. Note the color and location of the wires going to the driver. Remove the wire from the terminals on the driver. Remove the driver by turning it counterclockwise. Add new driver by turning it clockwise. Make sure that the male threads are greased. Reconnect the wires as previously noted. Reinstall the inspection plate.

PARTS LIST

MOD1004

ITEM	REQD	PART NO.	DESCRIPTION
1	1	8570003A	SPINNING, TOP
2	1	8570002A-01	SPINNING, FEMALE
3	1	8570001A	SPINNING, MALE
4	1	8570001A-01	SPINNING, MALE
5	4	8570005A	DOOR ACCESS
6	1	8570008C-01	PIPE BASE ASSY.
7	4	85700063A	FS 100W DRIVER
8	4	8570014A	GASKET, 1" ID.
9	1	7072A038	WASHER RUBBER
10	44	7074A067	LKWSHR SPLIT S.S.
11	46	700A345-16	SCREW, 25-20 S.S.
12	4	7059A010	STOP NUT, 25-20 S.S.
13	2	700A338-88	SCREW, 1/2-13
14	2	7074A025	LKWSHR SPLIT
15	2	7059A077	NUT, 1/2-13
16	1	7003A000-24	EYEBOLT
17	1	8570053A-01	U BRACKET ASSY.
18	1	8570006A	HORN/MOLDED
19	4	8570043B	HORN THROAT
20	1	8570010B	SCREEN/HORN
21	52	7072A024	WASH FLAT, S.S.
22	2	7099A103-15	POP RIVET, 1/8"
23	1	175728C-01	CABLE SIREN
24	1	7072A095	WASHER FLAT, 1/2"
25	4	7072A148A	WASH. FLT. NEOPRENE
26	2	161693A	LABEL FS
27	12	8570011A	U GASKET, SPINNING
28	01	R72-02-01	LOC TITE
29	04 OZ	R81-11-01	GREASE CONTACT
30	4	8570026A	NAMEPLATE
31	4	8570026A	RUBBER PAD
32	75 OZ	R70-08-03	RTV, SILICONE
33	11.67 FT	R42-04-01	GASKET, DOOR
34	4	150A146A	TIE WRAP
35	2	700A004-32	BOLT, 3/8-16 X 2
36	6	700A004-56	BOLT, 3/8-16 X 3-1/2
37	8	7057A032	NUT, STL 3/8
38	8	7072A036	WASHER FLAT 3/8
39	1	8291B016	BAG, POLY, 14X16
40	1	255253L	MANUAL
41	0	2561049A	SHEET CHECK LIST
42	1	8549A083A	ACCY. KIT MTG HDW
43	4	8549A170A	BRACKET ASSY, POLE MTG
44	2	T300214-09-009	T-WIRE, 46", WHT
45	2	161A507A	LABEL, WARNING
46	20	7065A049A	RIVNUT, 1/4-20
47	1	140530A	FITTING, 1" 90°, ALUM.

PARTS LIST

MOD2008

ITEM	REQD	PART NO.	DESCRIPTION
1	1	8570003A	SPINNING, TOP
2	1	8570002A-01	SPINNING, FEMALE
3	2	8570001A	SPINNING, MALE
4	1	8570001A-01	SPINNING, MALE
5	8	8570005A	DOOR ACCESS
6	1	8570008C-02	PIPE BASE ASSY.
7	8	85700063A	FS 100W DRIVER
8	8	8570014A	GASKET, 1" ID.
9	1	7072A038	WASHER RUBBER
10	80	7074A067	LKWSHR SPLIT S.S.
11	88	700A345-16	SCREW, 25-20 S.S.
12	8	7059A010	STOP NUT, 25-20 S.S.
13	2	700A338-88	SCREW, 1/2-13
14	2	7074A025	LKWSHR SPLIT
15	2	7059A077	NUT, 1/2-13
16	1	7003A000-24	EYEBOLT
17	1	8570053A-01	U BRACKET ASSY.
18	2	8570006A	HORN/MOLDED
19	8	8570043B	HORN THROAT
20	2	8570010B	SCREEN/HORN
21	96	7072A024	WASH FLAT, S.S.
22	2	7099A103-15	POP RIVET, 1/8"
23	1	175728C-02	CABLE SIREN
24	1	7072A095	WASHER FLAT, 1/2"
25	1	8570002A	SPINNING, FEMALE
26	2	161693A	LABEL FS
27	16	8570011A	U GASKET, SPINNING
28	01	R72-02-01	LOC TITE
29	06 OZ	R81-11-01	GREASE CONTACT
30	1	81461331A-02	NAMEPLATE
31	8	8570026A	RUBBER PAD
32	1.5 OZ	R70-08-03	RTV, SILICONE
33	23.34 FT	R42-04-01	GASKET, DOOR
34	8	150A146A	TIE WRAP
35	8	7072A148A	WASH. FLT. NEOPRENE
36	2	700A004-32	BOLT, 3/8-16 X 2
37	6	700A004-56	BOLT, 3/8-16 X 3-1/2
38	8	7057A032	NUT, STL 3/8
39	8	7072A036	WASHER FLAT 3/8
40	1	8291B016	BAG, POLY, 14X16
41	1	255253L	MANUAL
42	0	2561049A	SHEET CHECK LIST
43	1	8549A083A	ACCY. KIT MTG HDW
44	4	8549A170A	BRACKET ASSY, POLE MTG
45	4	T300214-09-009	T-WIRE, 46", WHT
46	2	161A507A	LABEL, WARNING
47	36	7065A049A	RIVNUT, 1/4-20
48	1	140530A	FITTING, 1" 90°, ALUM.

PARTS LIST

MOD3012

ITEM	REQD	PART NO.	DESCRIPTION
1	1	8570003A	SPINNING, TOP
2	1	8570002A-01	SPINNING, FEMALE
3	3	8570001A	SPINNING, MALE
4	1	8570001A-01	SPINNING, MALE
5	12	8570005A	DOOR ACCESS
6	1	8570008C-03	PIPE BASE ASSY.
7	12	85700063A	FS 100W DRIVER
8	12	8570014A	GASKET, 1" ID.
9	1	7072A038	WASHER RUBBER
10	116	7074A067	LKWSHR SPLIT S.S.
11	128	700A345-16	SCREW, 25-20 S.S.
12	12	7059A010	STOP NUT, 25-20 S.S.
13	2	700A338-88	SCREW, 1/2-13
14	2	7074A025	LKWSHR SPLIT
15	2	7059A077	NUT, 1/2-13
16	1	7003A000-24	EYEBOLT
17	1	8570053A-01	U BRACKET ASSY.
18	3	8570006A	HORN/MOLDED
19	12	8570043B	HORN THROAT
20	3	8570010B	SCREEN/HORN
21	140	7072A024	WASH FLAT, S.S.
22	2	7099A103-15	POP RIVET, 1/8"
23	1	175728C-03	CABLE SIREN
24	1	7072A095	WASHER FLAT, 1/2"
25	2	8570002A	SPINNING, FEMALE
26	2	161693A	LABEL FS
27	20	8570011A	U GASKET, SPINNING
28	01	R72-02-01	LOC TITE
29	1 OZ	R81-11-01	GREASE CONTACT
30	1	81461331A-03	NAMEPLATE
31	12	8570026A	RUBBER PAD
32	2.25 OZ	R70-08-03	RTV, SILICONE
33	35 FT	R42-04-01	GASKET, DOOR
34	12	150A146A	TIE WRAP
35	12	7072A148A	WASH. FLT. NEOPRENE
36	2	700A004-32	BOLT, 3/8-16 X 2
37	6	700A004-56	BOLT, 3/8-16 X 3-1/2
38	8	7057A032	NUT, STL 3/8
39	8	7072A036	WASHER FLAT 3/8
40	1	8291B016	BAG, POLY, 14X16
41	1	255253L	MANUAL
42	0	2561049A	SHEET CHECK LIST
43	1	8549A083A	ACCY. KIT MTG HDW
44	4	8549A170A	BRACKET ASSY, POLE MTG
45	6	T300214-09-009	T-WIRE, 46", WHT
46	2	161A507A	LABEL, WARNING
47	52	7065A049A	RIVNUT, 1/4-20
48	1	140530A	FITTING, 1" 90°, ALUM.

Figure 4-1. Parts lists for MOD1004, MOD2008 & MOD3012
Refer to Figure 4-2 for parts locations

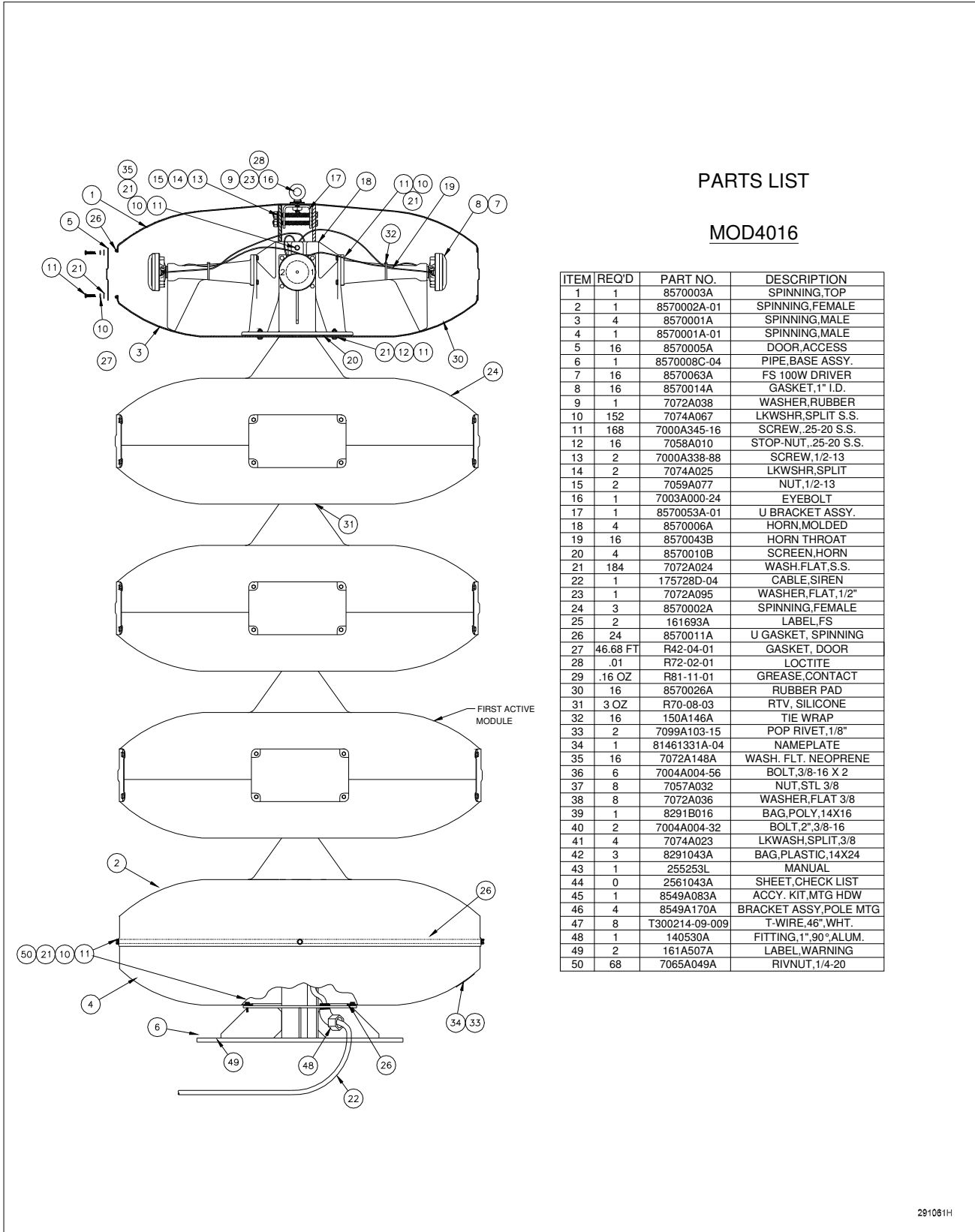

PARTS LIST

MOD4016

ITEM	REQ'D	PART NO.	DESCRIPTION
1	1	8570003A	SPINNING.TOP
2	1	8570002A-01	SPINNING.FEMALE
3	4	8570001A	SPINNING.MALE
4	1	8570001A-01	SPINNING.MALE
5	16	8570005A	DOOR.ACCESS
6	1	8570008C-04	PIPE.BASE ASSY.
7	16	8570063A	FS 100W DRIVER
8	16	8570014A	GASKET,1" I.D.
9	1	7072A038	WASHER,RUBBER
10	152	7074A067	LKWSHR.SPLIT S.S.
11	168	7000A345-16	SCREW,25-20 S.S.
12	16	7058A010	STOP-NUT,25-20 S.S.
13	2	7000A338-88	SCREW,1/2-13
14	2	7074A025	LKWSHR.SPLIT
15	2	7059A077	NUT,1/2-13
16	1	7003A000-24	EYEBOLT
17	1	8570053A-01	U BRACKET ASSY.
18	4	8570006A	HORN,MOLDED
19	16	8570043B	HORN THROAT
20	4	8570010B	SCREEN,HORN
21	184	7072A024	WASH.FLAT,S.S.
22	1	175728D-04	CABLE,SIREN
23	1	7072A095	WASHER,FLAT,1/2"
24	3	8570002A	SPINNING.FEMALE
25	2	161693A	LABEL,FS
26	24	8570011A	U GASKET, SPINNING
27	46.68 FT	R42-04-01	GASKET, DOOR
28	.01	R72-02-01	LOCTITE
29	.16 OZ	R81-11-01	GREASE,CONTACT
30	16	8570026A	RUBBER PAD
31	3 OZ	R70-08-03	RTV, SILICONE
32	16	150A146A	TIE WRAP
33	2	7099A103-15	POP RIVET,1/8"
34	1	81461331A-04	NAMEPLATE
35	16	7072A148A	WASH. FLT. NEOPRENE
36	6	7004A004-56	BOLT,3/8-16 X 2
37	8	7057A032	NUT,STL 3/8
38	8	7072A036	WASHER,FLAT 3/8
39	1	8291B016	BAG.POLY,14X16
40	2	7004A004-32	BOLT,2",3/8-16
41	4	7074A023	LKWASH.SPLIT,3/8
42	3	8291043A	BAG.PLASTIC,14X24
43	1	255253L	MANUAL
44	0	2561043A	SHEET,CHECK LIST
45	1	8549A083A	ACCY. KIT.MTG HDW
46	4	8549A170A	BRACKET ASSY.POLE MTG
47	8	T300214-09-009	T-WIRE,46",WHT.
48	1	140530A	FITTING,1",90",ALUM.
49	2	161A507A	LABEL,WARNING
50	68	7065A049A	RIVNUT,1/4-20

Figure 4-2. Model MOD4016 Parts Location Diagram

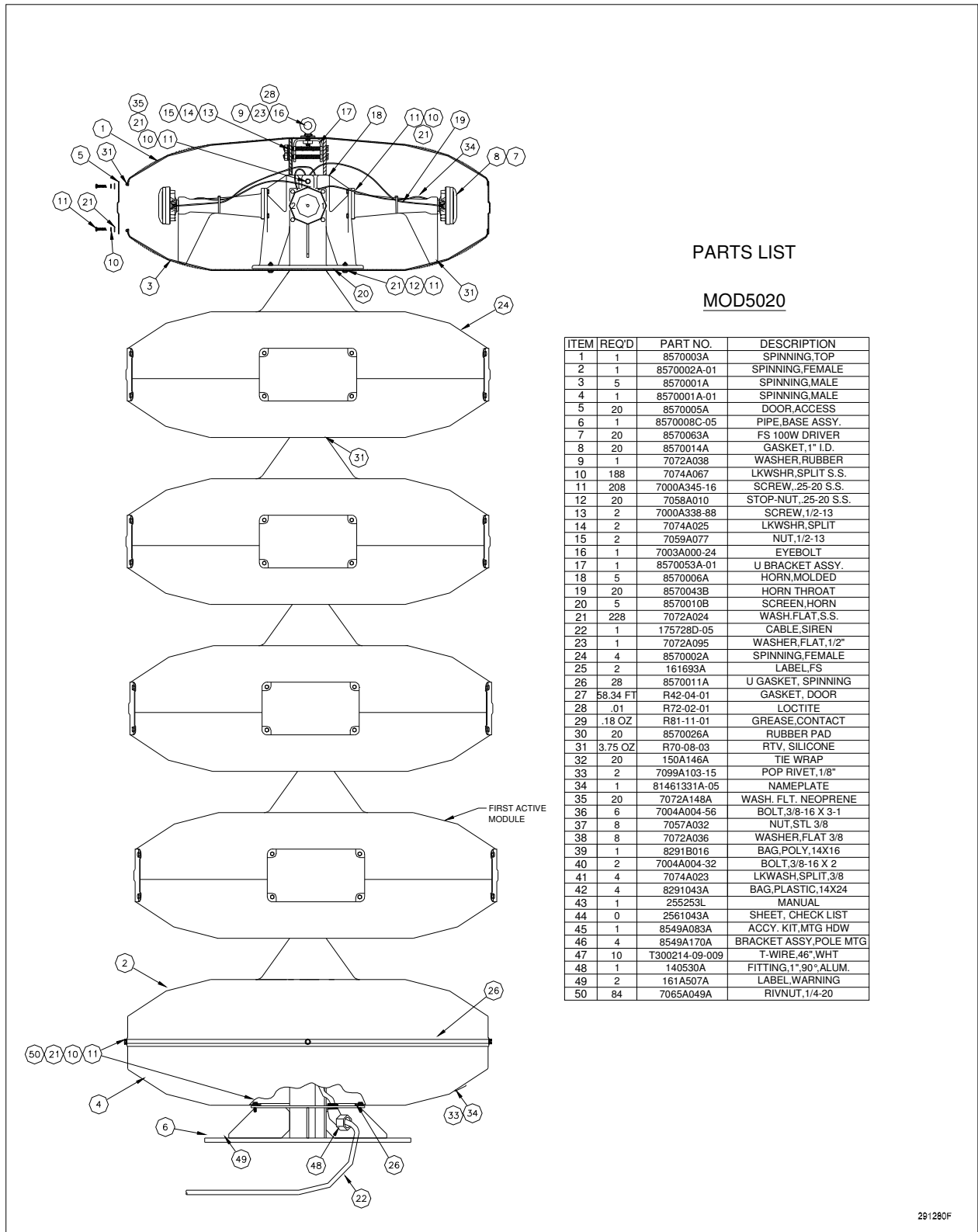

Figure 4-3. Model MOD5020 Parts Location Diagram

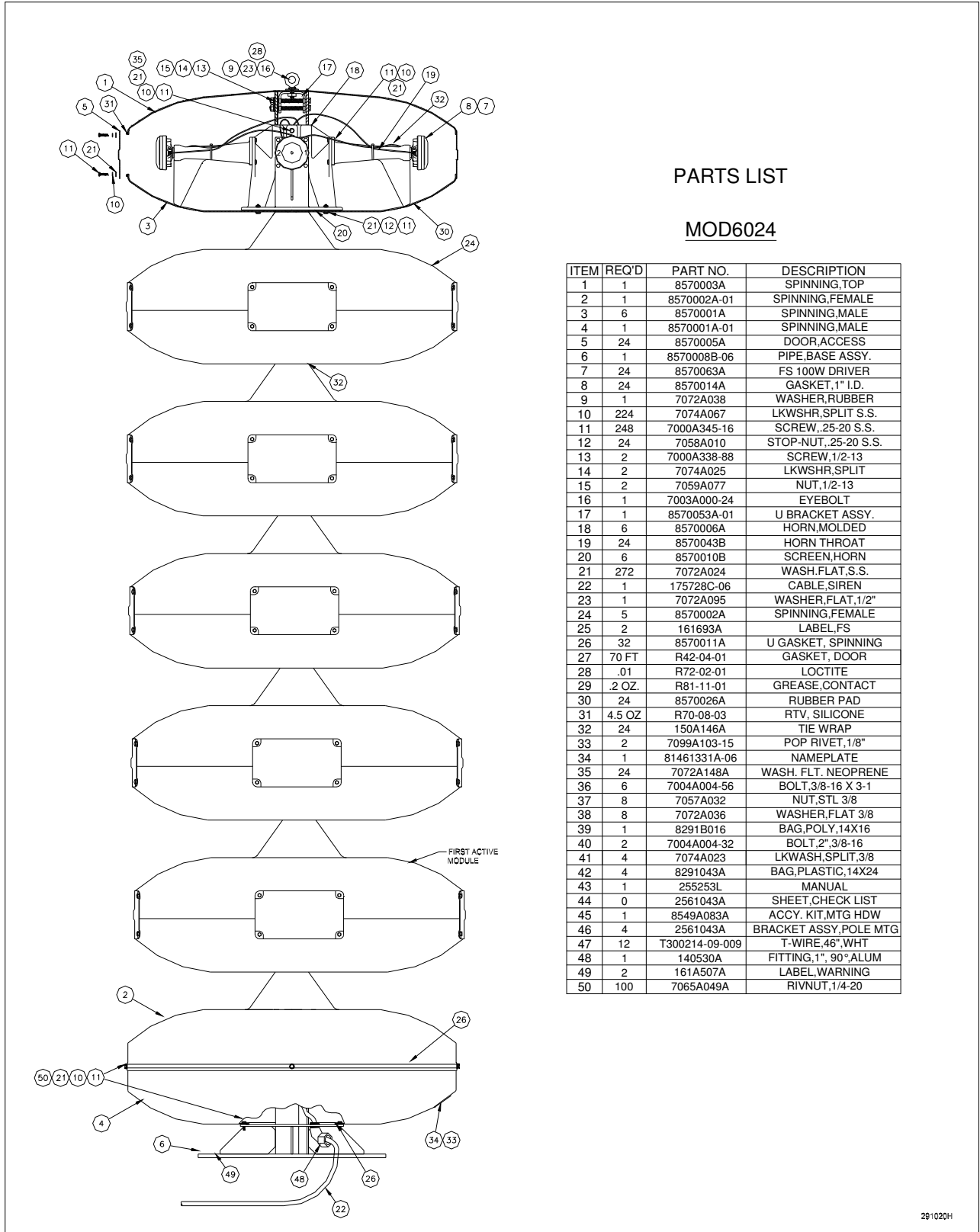

Figure 4-4. Model MOD6024 Parts Location Diagram

PARTS LIST

MOD6032

ITEM	REQ'D	PART NO.	DESCRIPTION
1	1	8570003A	SPINNING, TOP
2	1	8570002A-01	SPINNING, FEMALE
3	6	8570001A	SPINNING, MALE
4	1	8570001A-01	SPINNING, MALE
5	24	8570005A	DOOR, ACCESS
6	1	8570008C-06	PIPE, BASE ASSY.
7	32	8570063A	FS 100W DRIVER
8	40	8570014A	GASKET, 1" I.D.
9	1	7072A038	WASHER, RUBBER
10	224	7074A067	LKWSHR, SPLIT S.S.
11	248	7000A345-16	SCREW, .25-20 S.S.
12	24	7058A010	STOP-NUT, .25-20 S.S.
13	2	7000A338-88	SCREW, 1/2-13
14	2	7074A025	LKWSHR, SPLIT
15	2	7059A077	NUT, 1/2-13
16	1	7003A000-24	EYEBOLT
17	1	8570053A-01	U BRACKET ASSY.
18	6	8570006A	HORN, MOLDED
19	24	8570043B	HORN THROAT, SHORT
20	6	8570010B	SCREEN, HORN
21	272	7072A024	WASH. FLAT, S.S.
22	1	175728B-48	CABLE, SIREN
23	1	7072A095	WASHER, FLAT, 1/2"
24	5	8570002A	SPINNING, FEMALE
25	2	161693A	LABEL, FS
26	32	8570011A	U GASKET, SPINNING
27	70 FT	R42-04-01	GASKET, DOOR
28	.01	R72-02-01	LOCTITE
29	.4 OZ.	R81-11-01	GREASE, CONTACT
30	24	8570026A	RUBBER PAD
31	4.5 OZ	R70-08-03	RTV, SILICONE
32	48	150A146A	TIE WRAP
33	2	7099A103-15	POP RIVET, 1/8"
34	1	81461331A-13	NAMEPLATE
35	24	7072A148A	WASH. FLT. NEOPRENE
36	8	8542A108A	COUPLER, DRIVER
37	1	140530A	FITTING, 1", 90D. ALUM.
38	6	7004A004-56	BOLT 3/8-16 X 3-1
39	8	7057A032	NUT, STL 3/8
40	8	7072A036	WASHER, FLAT 3/8
41	1	8291B016	BAG, POLY, 14X16
42	2	7004A004-32	BOLT, 3/8-16 X 2
43	4	7074A023	LKWASH, SPLIT, 3/8
44	8	8291043A	BAG, PLASTIC, 14X24
45	8	T300218-09-085	WIRE, 18 GA., 13'
46	1	255253L	MANUAL
47	0	2561043A	SHEET, CHECK LIST
48	1	8549A083A	ACCY. KIT, MTG HDW
49	4	8549A170A	BRACKET ASSY, POLE MTG
50	2	161A507A	LABEL, WARNING
51	100	7065A049A	RIVNUT, 1/4-20
52	8	T300214-09-009	T-WIRE, 18GA, WHT, 46"

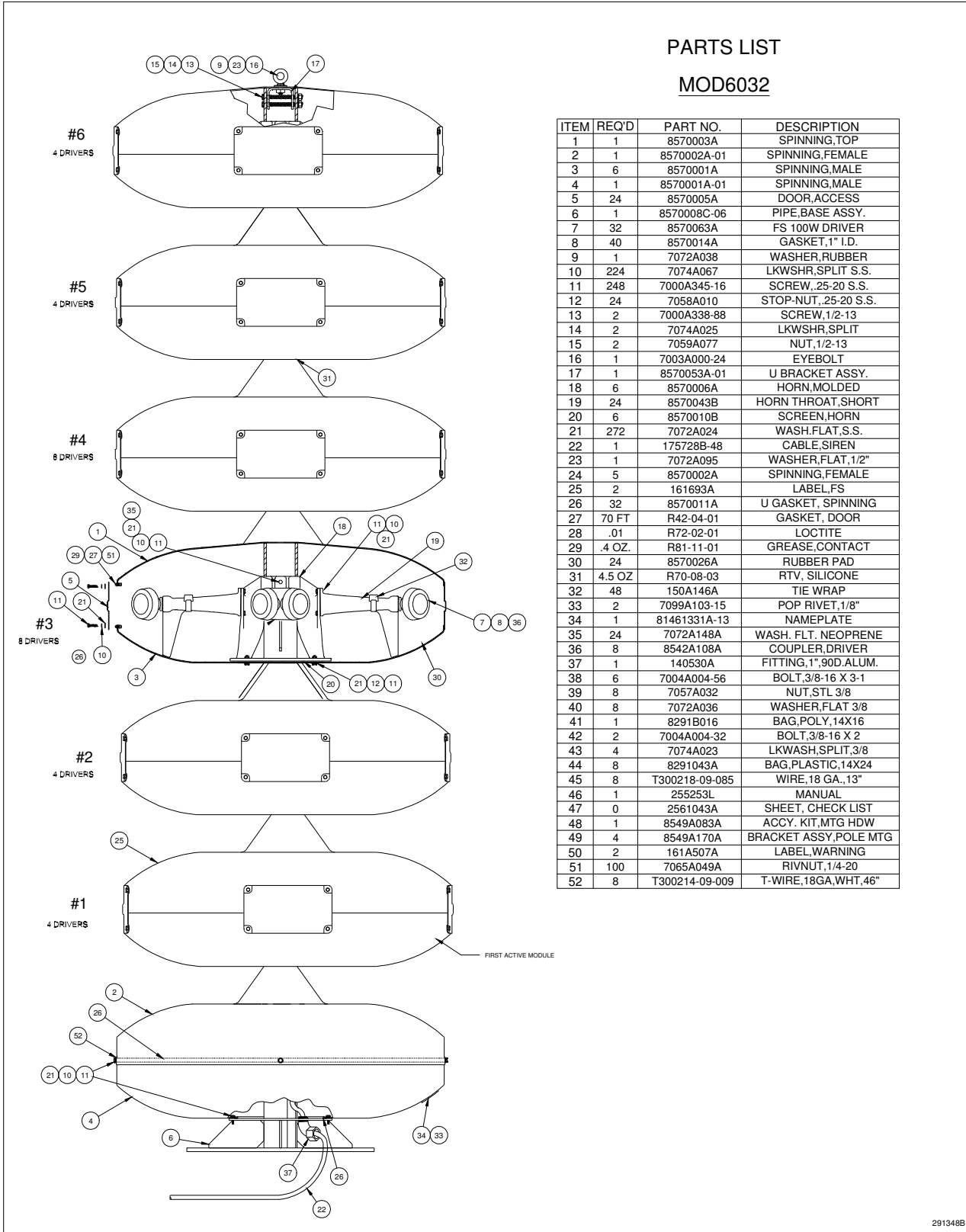
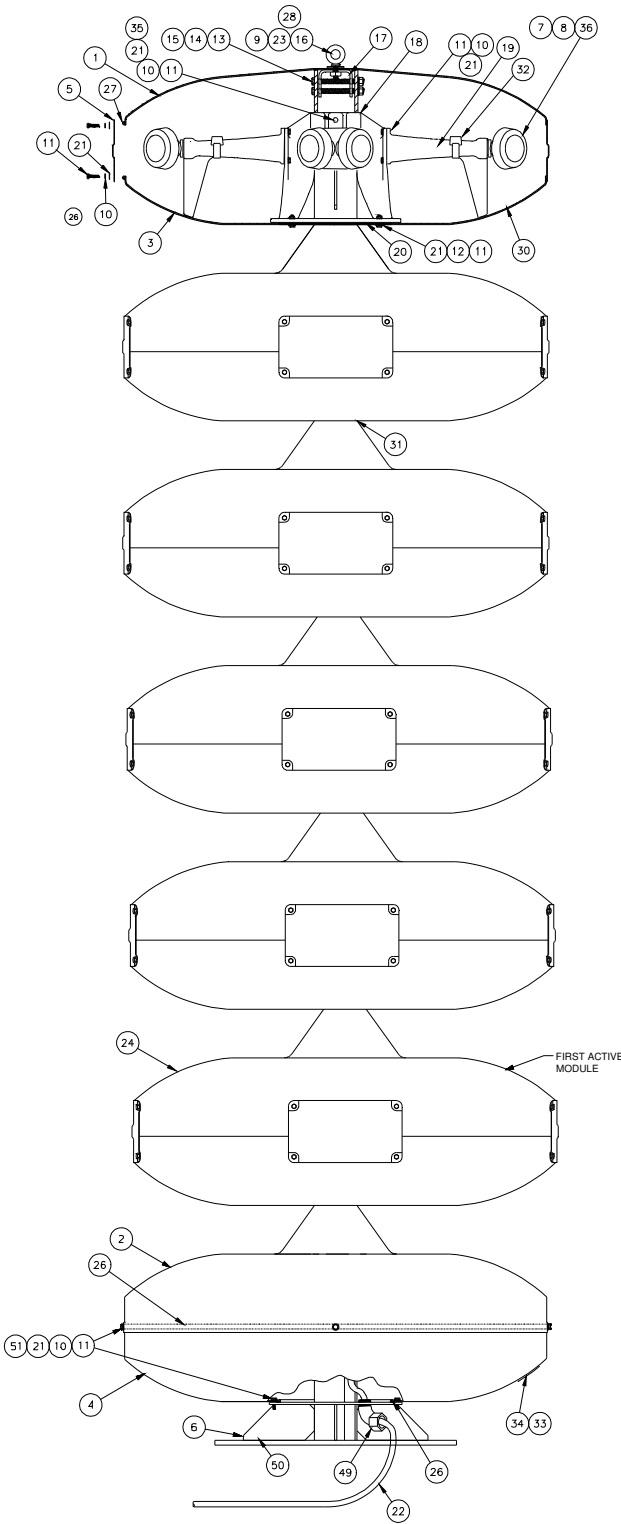

Figure 4-5. Model MOD6032 Parts Location Diagram

PARTS LIST

MOD6048



ITEM	REQ'D	PART NO.	DESCRIPTION
1	1	8570003A	SPINNING, TOP
2	1	8570002A-01	SPINNING, FEMALE
3	6	8570001A	SPINNING, MALE
4	1	8570001A-01	SPINNING, MALE
5	24	8570005A	DOOR, ACCESS
6	1	8570008C-06	PIPE, BASE ASSY.
7	48	8570063A	FS 100W DRIVER
8	72	8570014A	GASKET, 1" I.D.
9	1	7072A038	WASHER, RUBBER
10	224	7074A067	LKWSHR, SPLIT S.S.
11	248	7000A345-16	SCREW, .25-20 S.S.
12	24	7058A010	STOP-NUT, .25-20 S.S.
13	2	7000A338-88	SCREW, 1/2-13
14	2	7074A025	LKWSHR, SPLIT
15	2	7059A077	NUT, 1/2-13
16	1	7003A000-24	EYEBOLT
17	1	8570053A-01	U BRACKET ASSY.
18	6	8570006A	HORN, MOLDED
19	24	8570043B	HORN THROAT, SHORT
20	6	8570010B	SCREEN, HORN
21	272	7072A024	WASH, FLAT, S.S.
22	1	175728B-48	CABLE, SIREN
23	1	7072A095	WASHER, FLAT, 1/2"
24	5	8570002A	SPINNING, FEMALE
25	2	161693A	LABEL, FS
26	32	8570011A	U GASKET, SPINNING
27	70 FT	R42-04-01	GASKET, DOOR
28	.01	R72-02-01	LOCTITE
29	.4 OZ.	R81-11-01	GREASE, CONTACT
30	24	8570026A	RUBBER PAD
31	4.5 OZ	R70-08-03	RTV, SILICONE
32	48	150A146A	TIE WRAP
33	2	7099A103-15	POP RIVET, 1/8"
34	1	81461331A-11	NAMEPLATE
35	24	7072A148A	WASH. FLT. NEOPRENE
36	24	8542A108A	COUPLER, DRIVER
37	6	7004A004-56	BOLT, 3/8-16 X 3-1
38	8	7057A032	NUT, STL 3/8
39	8	7072A036	WASHER, FLAT 3/8
40	1	8291B016	BAG, POLY, 14X16
41	2	7004A004-32	BOLT, 3/8-16 X 2
42	4	7074A023	LKWASH, SPLIT, 3/8
43	8	8291043A	BAG, PLASTIC, 16X24
44	24	T300218-09-085	WIRE, 18 GA., 13"
45	1	255253L	MANUAL
46	0	2561043A	SHEET, CHECK LIST
47	1	8549A083A	ACCY. KIT, MTG HDW
48	4	8549A170A	BRACKET ASSY, POLE MTG
49	1	140530A	FITTING, 1", 90D ALUM.
50	2	161A507A	LABEL, WARNING
51	100	7065A049A	RIVNUT, 1/4-20

Figure 4-6. Model MOD6048 Parts Location Diagram